



**DAIKIN APPLIED (UK) LTD**

EWYE-CZ

**R-454C**

# Air to Water Inverter Heat Pump



High temperature & low carbon solution  
for heating decarbonisation



Product page

## AIR TO WATER HEAT PUMP

# High temperature & low carbon solution

### High temperature Heat Pump

Heat Pump version with one and two independent refrigerant circuits characterised by the optimised and compact design from 1 to 4 fans in line.



Heat pump version



### Capacity range and layout



19-25 kW



30-35 kW



50-60 kW



70 kW

### Installation flexibility

The new R-454C small inverter heat pump EWYE-CZ is available in 4 compact versions, all of which have a very small footprint despite the performance capacity they can deliver. This makes the range a great solution for projects where space is at a premium, such as: residential, hotels and hospitals. No additional safety measures are required as R-454C is an A2L refrigerant like the widely used R-32.

### Product overview

The most complete and unique solution on the market for decarbonisation. EWYE-CZ reaches 70 °C of heating water temperature even in extreme ambient conditions. That is, during winter season in Nordic countries (low ambient temperature) and even in summer when Domestic Hot Water production would still be required. Moreover, EWYE-CZ can work in high delta T conditions allowing the supply of heating water to different heating applications in the installation space.

EWYE-CZ is available in 8 sizes from 16 to 70 kW capacity, all equipped with Daikin inverter scroll compressors. As well, fans used on EWYE-CZ are designed by Daikin. The product range also integrates an inverter water pump, facilitating installation operations and saving space.

The product is also available in reduced noise configuration, particularly suitable for noise-sensitive applications as: residential buildings, hotels and hospitals. Comfort heating can be supplied in many different applications, and on top of that EWYE-CZ allows domestic hot water production, including anti-legionella control function for the external storage tank.

### Operating range

	Min	Max
Heating water	20°C	70°C
Ambient temperature OAT	-25°C	40°C

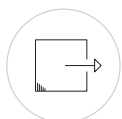

Outdoor installation



Daikin tubes and fins (Cu/Al coil)



Daikin VFD scroll



Daikin EC fans



Integrated VFD pump



Refrigerant

# Product Benefits

## Daikin core technology

**Daikin scroll compressors** can benefit from inverter technology that increases this series' efficiency performance, while the vapor injection with economiser guarantees the series capacity steps and extended operating heating envelope.

Great energy efficiency levels are also granted by the **Daikin inverter driven fans**, with high efficiency design glass reinforced resin to maximise performances.

**Daikin inverter scroll compressors** and pump with vapor injection, make this new R-454C small inverter heat pump a full inverter series.

**Daikin tube & fins (Cu/Al) heat exchanger:** reversible heat exchanger optimised for most extreme heating operation. Aluminum fins are covered by acrylic layer to ease flowing of condensate moisture and provide resistance to corrosion and protection from uv.

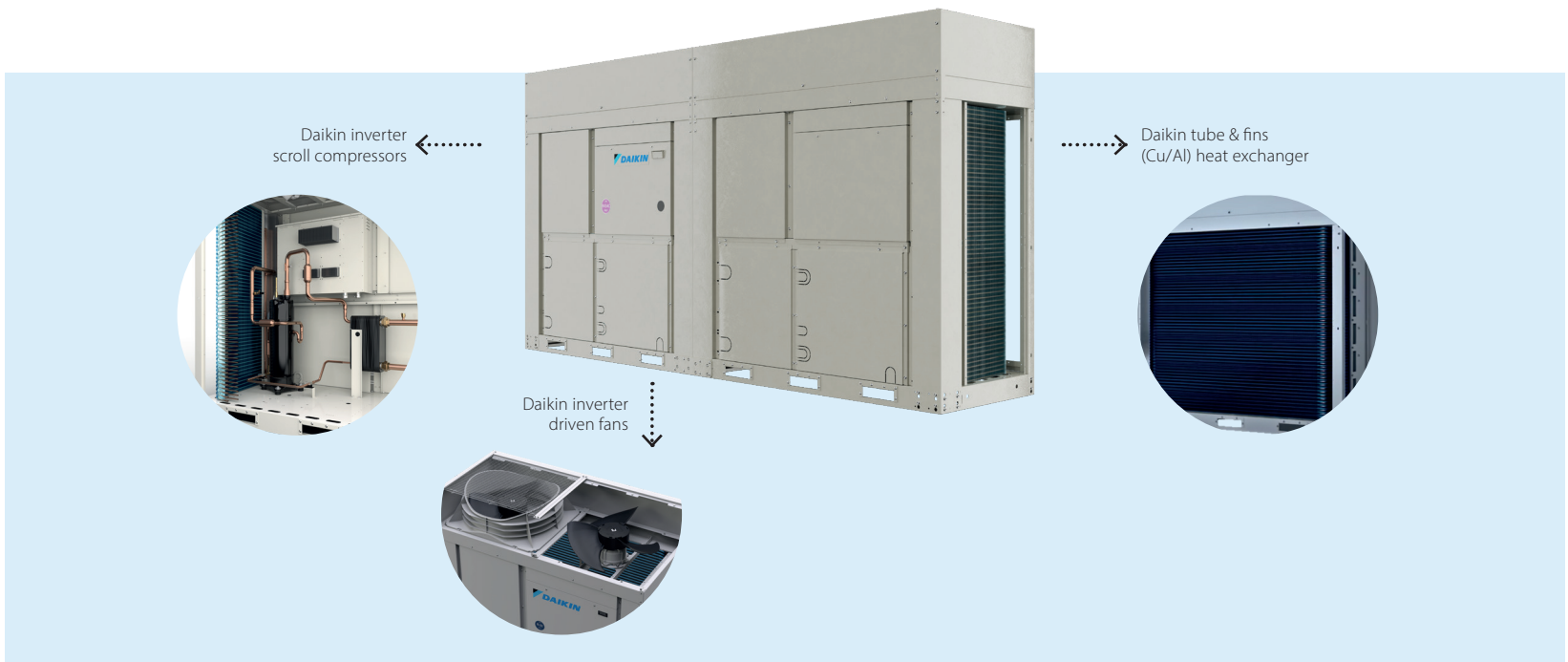

## New compressor technology with vapor injection

Refrigerant piping diagram with economiser for vapor injection

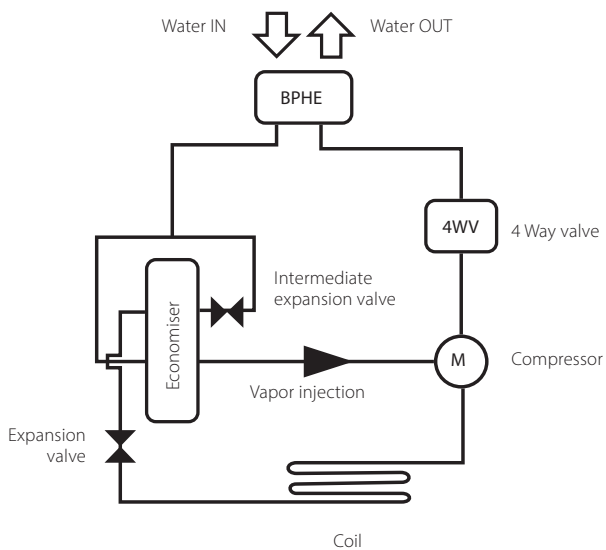

Refrigerant cycle with vapor injection

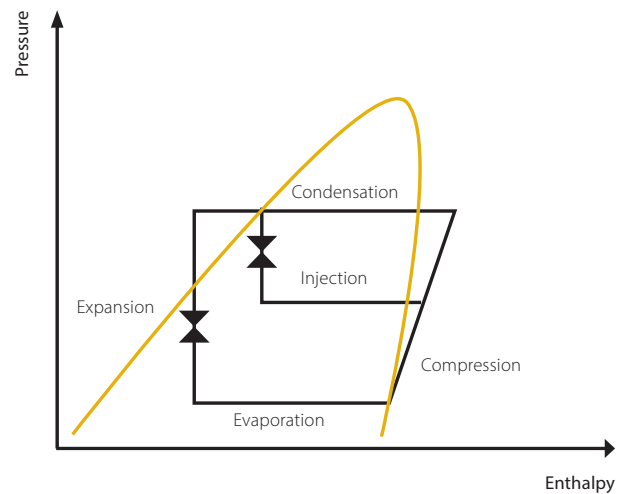



### Optimised defrost management

Integrated defrost logic optimised for multiple units to sequence the non-simultaneity of the defrost cycle. Plant up to 4 units are optimised in terms of overall defrost impact:

- Less plant water content
- Higher customer comfort due to minimised temperature drop
- Heating load uniformity over time

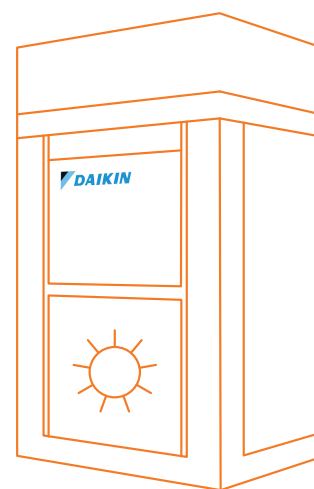

### Low operating costs

Thanks to its full inverter design, this new unit can closely follow the cooling and heating load profile of the building. This is particularly important as it ensures low operating costs for the HVAC system at part load conditions, which represent most of the operating time.

### F-gas Ready Solution

The new Small Inverter Heat Pump provides low direct and indirect CO<sub>2</sub> emissions levels. That makes it an environmentally friendly series, also thanks to the use of R-454C, which is known for being a low GWP (145.5) and sustainable refrigerant, fully compliant with the new F-gas regulation.



### Contribution to Green Building

The most popular green building protocols are BREEAM and LEED. EWYE-CZ can contribute to project's credits when evaluating energy efficiency of the hydronic system, thanks to inverter driven compressors. The limited GWP of R-454C also result in a possible contribution when evaluating the impact of refrigerants. On top of that, the smart grid accessory allows to control the heat pump maximising consumptions when renewable energy is produced. Thereby, potentially resulting in credits under BREEAM and LEED protocols, as carbon footprint would be reduced.



# Product applications

## High temperature heating for boiler replacement and domestic hot water (DHW)

### Space heating + DHW configurations

- Centralised heating, eventually in combination with gas boilers. DHW supply managed via integration with centralised heating, or independent DHW supply. Groups of units can be managed in master / slave up to 4 per single master
- Applications: residential, light commercial, hotels, gym
- Installation: replacement and new building
- Possible terminals are:
  - Existing radiators (70 °C)
  - Heating floor (30-35 °C)
  - Fan coils (40-45 °C)

**Centralised heating**  
Standard configuration

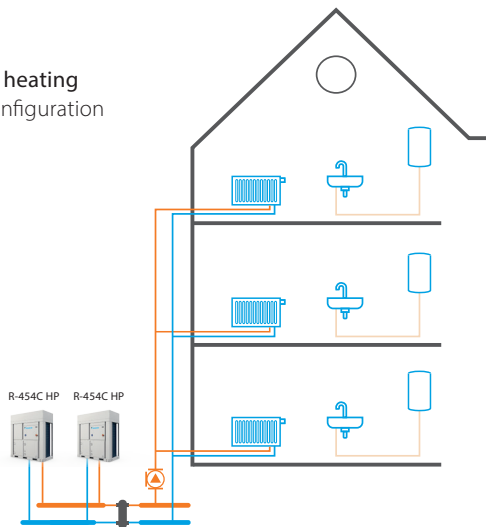

**Centralised heating (Hybrid solution with gas boiler)**  
Dedicated accessory for bivalent operation to be added

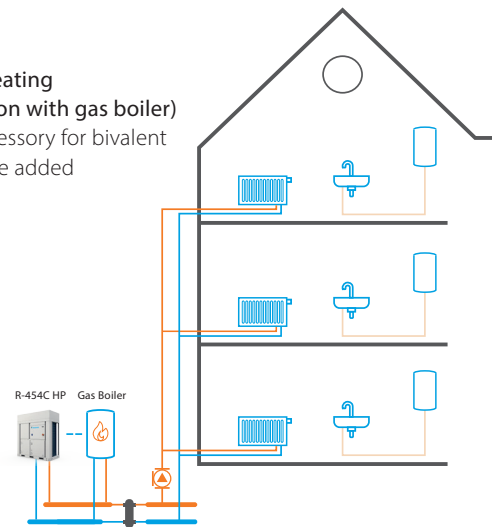

**Centralised heating and DHW production**  
Dedicated accessory for DHW to be added

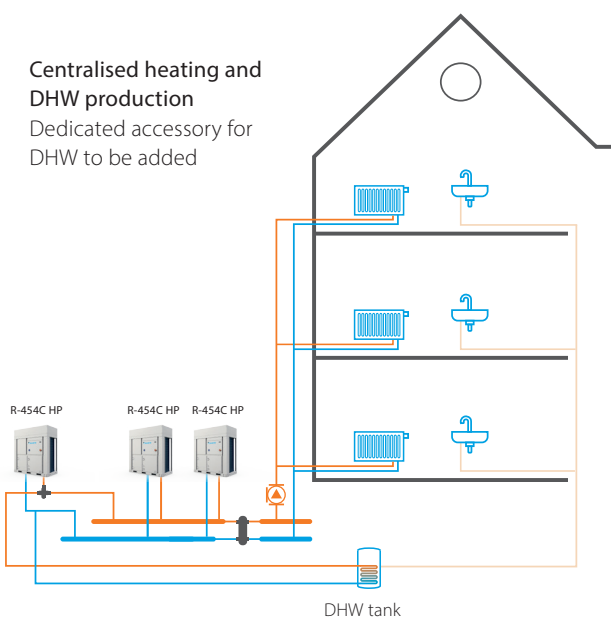

**Centralised heating and DHW production (dedicated generator for DHW)**  
Dedicated accessory for DHW to be added

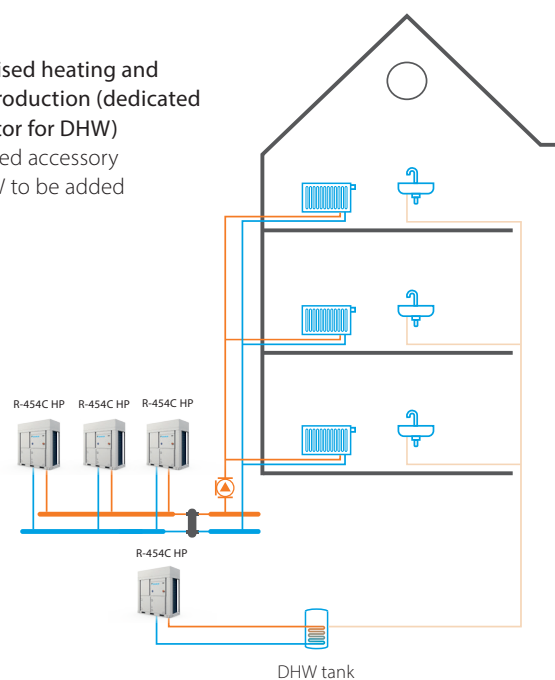

Preliminary information, subject to change. Final data will be released at product launch.

# Product applications

## Seasonal comfort heating and cooling + domestic hot water (DHW)

### Comfort cooling & heating

- Centralised comfort heating and cooling. DHW managed via three way valves (priority on DHW demand) or independent DHW supply. Groups of units can be managed in master / slave up to 4 per single master
- Applications: residential, light commercial, hotels, gym
- Installation: replacement and new building
- Possible terminals are:
  - Cooling (23-18°C) and heating floor (30-35°C)
  - Heating and cooling fan coils

**Centralised cooling and heating**  
Standard configuration

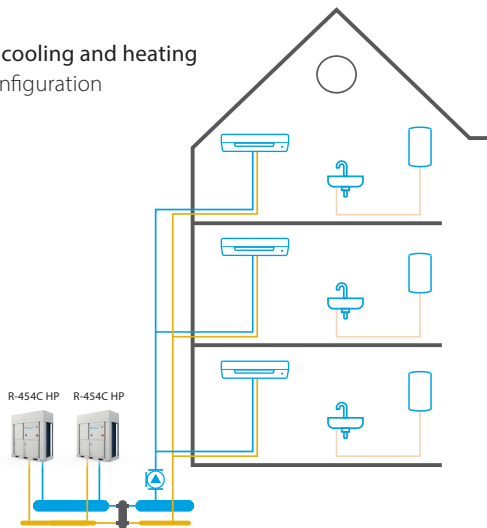

**Centralised cooling, heating and DHW production**  
Dedicated accessory for DHW to be added

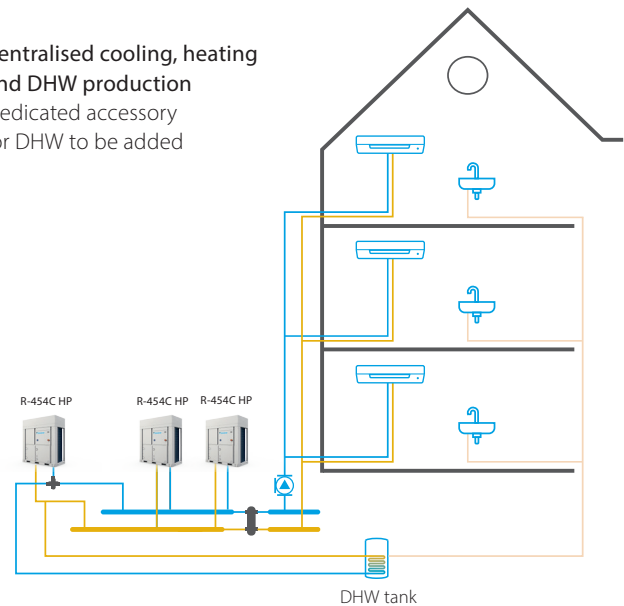

**Centralised cooling, heating, and dhw production (dedicated generator for dhw)**  
Dedicated accessory for DHW to be added

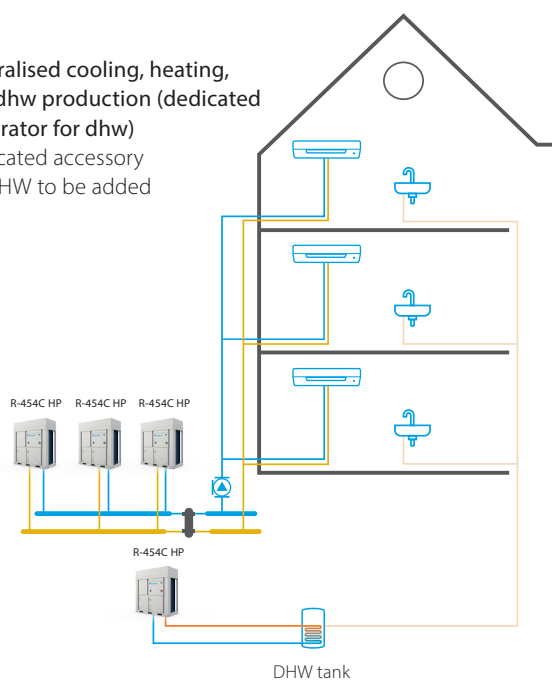

# Product options and accessories

## Standard on CZP version

### Hydronic kit

The Small Inverter Heat Pump is equipped with an inverter pump on board with electrical protection as standard. Possibility to order the unit also without the pump.

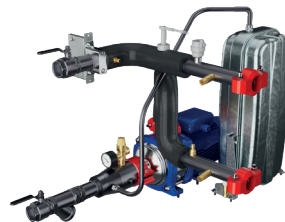

## Plant management & connectivity

Master / slave or Modbus RTU are standard to ensure a perfect plant connectivity.

Remote monitoring and system optimisation with Daikin proprietary cloud platform Daikin On Site.

- Predictive maintenance to prevent breakdowns
- Visualise energy consumption to reduce energy costs
- Monitor and control your building no matter where you are via the Daikin On Site
- Remote diagnostic support to increase your system lifetime
- Manage multiple sites



### Dashboards

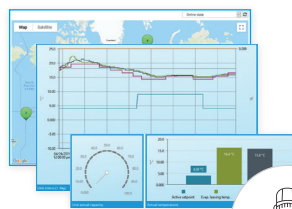

Operator

### Diagnostics

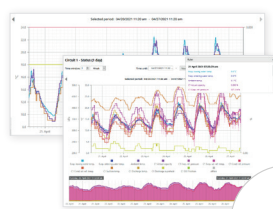

Service

### Remote software upgrade

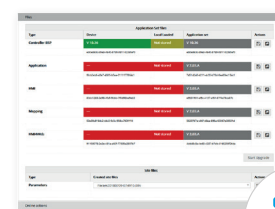

Daikin

## Master / slave control

The Small Inverter Heat Pump is able to operate in master/slave mode optimising the plant operation up to 4 units. The master unit manages the slave units connected in parallel on the same hydraulic plant balancing the running hours and load of each unit and each compressor.

# Product options and accessories

## On-demand

mAP mobile APP for HMI controller extension towards end users



HMI APP is available on smartphone and tablet devices for close monitoring of unit parameters up to 5 meters

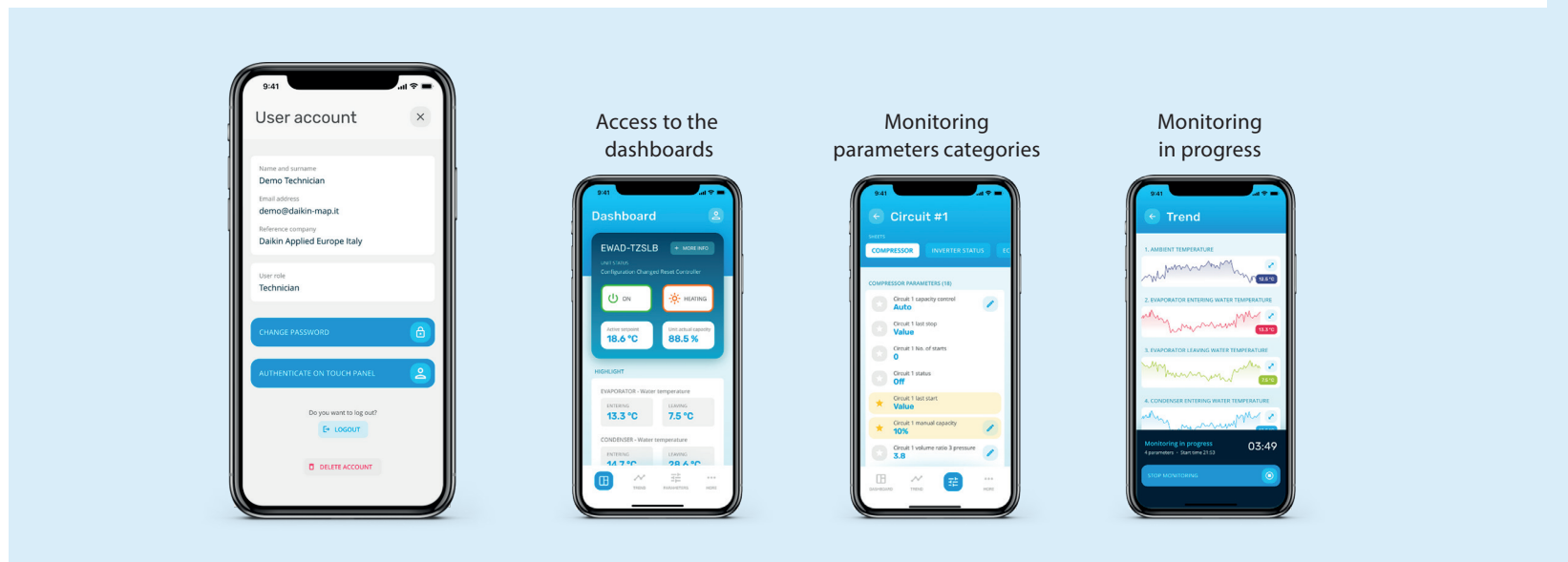

### Plug & play connectivity

When ordering the connectivity kit, you will receive a connectivity card. The card will report a unique activation ID (QR code) identifying the license for a specific Small Inverter Heat Pump unit controller. The unit controller has a sticker that must be put on the connectivity card in order to use it with the app.

### Smart grid ready box

The smart grid box is an accessory that allows the integration of the heat pump control for a smart grid application, maximising use of green energy to run the heat pump.

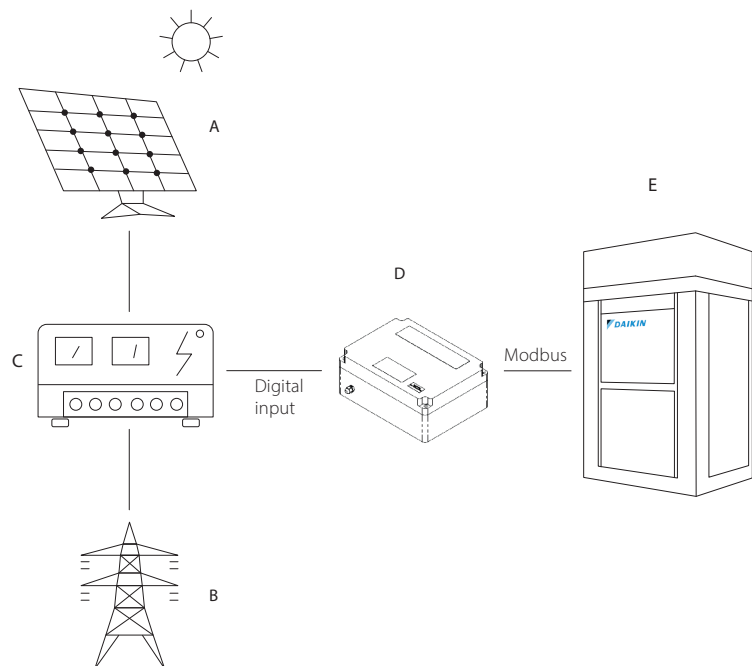

- A: Solar panels
- B: Grid
- C: Interface-compatible system components (Solar inverter / energy management system)
- D: Smart grid box
- E: Heat pump

# Plant water content

The heating system should maintain a minimum water content to prevent a significant reduction of the water setpoint during the defrosting cycle, ensuring proper environmental comfort. As a general guide, the water content of the system should not be lower than the values obtained from the following formula:

$$kW_{nominal} = \text{Heating capacity at } 40/45^{\circ}\text{C OAT}=7^{\circ}\text{C}$$

The above rule of thumb derives from the following formula, as the relative volume of water capable of maintaining the system temperature within an acceptable  $\Delta T$  (which depends on the heating application) during the defrost transient.

$$\begin{aligned} \text{Single circuit unit} &\longrightarrow 16 \frac{\text{lt}}{\text{kW}_{nominal}} \\ \text{Dual circuit unit} &\longrightarrow 8 \frac{\text{lt}}{\text{kW}_{nominal}} \end{aligned}$$

$$\text{Water volume} = \frac{CC [W] * MDD [s]}{FD \left[\frac{g}{L}\right] * SH \left[\frac{J}{g^{\circ}C}\right] * (DT)[^{\circ}C]}$$

- CC = Cooling capacity during defrost operation
- MDD = Max defrost duration
- FD = Fluid density
- SH = Specific heat
- DT = Acceptable water temperature differential

The water temperature difference is considered acceptable for the comfort heating application which allows to operate with the minimum volume mentioned in the previous formula. However, if a smaller water temperature difference is considered acceptable, a larger minimum water volume will be required. A properly designed storage tank should be added if the system components do not provide sufficient water volume. In case of more than one installed unit, the overall capacity of the installation must be considered in the calculation so summing the water content of each unit. These considerations refer to the water volume always flowing through the unit. If there are bypasses, branch of the system that can be excluded, that parts should not be accounted in the water content calculation.

## Product dimensions



Model	Dimensions (mm)
EWYE019CZ(N)(P)-A1	1,878 x 1,152 x 802
EWYE022CZ(N)(P)-A1	1,878 x 1,152 x 802
EWYE025CZ(N)(P)-A1	1,878 x 1,152 x 802
EWYE030CZ(N)(P)-A1	1,878 x 1,152 x 802
EWYE035CZ(N)(P)-A1	1,878 x 1,152 x 802
EWYE050CZ(N)(P)-A2	1,878 x 2,906 x 814
EWYE060CZ(N)(P)-A2	1,878 x 2,906 x 814
EWYE070CZ(N)(P)-A2	1,878 x 3,506 x 814

Minimum access distances to be respected: 500 mm all around the unit (single unit installation) or 1,000 mm from each condensing section in case of multiple units' installation.

# Technical data

Inverter pump on board			EWYE019 CZP-A1	EWYE022 CZP-A1	EWYE025 CZP-A1	EWYE030 CZP-A1	EWYE035 CZP-A1	EWYE050 CZP-A2	EWYE060 CZP-A2	EWYE070 CZP-A2	
Cooling performance 12/7 35°C	Cooling capacity	kW	14,88	16,42	18,24	22,45	25,66	42,11	46,90	59,62	
	Capacity control	Type	Inverter controlled								
	Unit power input		5,39	6,03	6,64	7,39	8,90	15,69	17,86	22,35	
	EER		2,76	2,73	2,75	3,04	2,88	2,68	2,63	2,67	
	SEER		3,88	3,94	4,07	4,60	4,66	4,22	4,42	4,66	
Heating performance 40/45 7°C	Heating capacity		18,21	20,25	23,93	29,72	34,35	49,89	59,58	73,27	
	Unit power input	Heating kW	5,86	6,51	7,66	8,92	10,56	16,35	20,34	24,42	
	COP		3,11		3,13	3,33	3,25	3,05	2,93	3,00	
Space heating	Average climate, water outlet 35°C	SCOP	Low temperature		4,00		4,38		3,87		4,06
	Average climate, water outlet 55°C	SCOP	Medium temperature		2,83		3,20		2,83		3,02
Water heat exchanger cooling	Water flow rate	l/s	0,70	0,77	0,84	1,06	1,21	1,99	2,16	2,77	
	Water pressure drop	kPa	6,05	7,19	8,41	9,82	12,41	10,01	11,62	9,51	
Water heat exchanger heating	Water flow rate	l/s	0,87	0,97	1,11	1,42	1,61	2,35	2,77	3,45	
	Water pressure drop	kPa	9,03	10,89	13,77	16,40	20,53	13,57	18,38	14,38	
Air heat changer	Type	Al fins & Cu tubes									
Water heat exchanger	Braze plate										
Refrigerant	Type	R-454C									
	GWP	145,5									
Compressor	Type	Scroll - Vapor injection									
	Quantity	N°	1					2		2	
	Economiser	N°	1					2		2	
Fan	Type	Axial									
	Drive	VFD									
	Quantity	N°	1			2		3		4	
Dimensions	Height	mm	1878								
	Width	mm	802					814			
	Length	mm	1152			1752		2906		3506	
Sound power	Lw [dB(A)] **	77									
	Cooling & Heating Lw [dB(A)]	82	83					86			

No pump on board			EWYE019 CZN-A1	EWYE022 CZN-A1	EWYE025 CZN-A1	EWYE030 CZN-A1	EWYE035 CZN-A1	EWYE050 CZN-A2	EWYE060 CZN-A2	EWYE070 CZN-A2	
Cooling performance 12/7 35°C	Cooling capacity	kW	14,66	16,18	18,29	22,19	25,39	41,78	46,98	59,21	
	Capacity control	Type	Inverter controlled								
	Unit power input		5,43	6,07	6,69	7,43	8,96	15,81	17,76	22,30	
	EER		2,70	2,67	2,73	2,99	2,83	2,64	2,65	2,66	
	SEER		3,74	3,80	3,99	4,43	4,54	4,10	4,34	4,56	
Heating performance 40/45 7°C	Heating capacity		18,47	20,51	24,21	30,02	34,68	50,24	60,47	73,73	
	Unit power input	Heating kW	5,90	6,57	7,72	9,00	10,65	16,48	20,54	24,39	
	COP		3,13	3,12	3,14	3,34	3,26	3,05	2,94	3,02	
Space heating	Average climate, water outlet 35°C	SCOP	Low temperature		3,89		4,31		3,72		4,00
	Average climate, water outlet 55°C	SCOP	Medium temperature		2,83		3,20		2,83		3,01
Water heat exchanger cooling	Water flow rate	l/s	0,7	0,77	0,84	1,06	1,21	1,99	2,16	2,77	
	Water pressure drop	kPa	6,05	7,19	8,41	9,82	12,41	10,01	11,62	9,51	
Water heat exchanger heating	Water flow rate	l/s	0,87	0,97	1,11	1,42	1,61	2,35	2,80	3,45	
	Water pressure drop	kPa	9,03	10,89	13,77	16,40	20,53	13,57	18,76	14,38	
Air heat exchanger	Type	Al fins & Cu tubes									
Water heat exchanger	Braze plate										
Refrigerant	Type	R-454C									
	GWP	145,5									
Compressor	Type	Scroll - Vapor injection									
	Quantity	N°	1					2		2	
	Economiser	N°	1					2		2	
Fan	Type	Axial									
	Drive	VFD									
	Quantity	N°	1			2		3		4	
Dimensions	Height	mm	1878								
	Width	mm	802					814			
	Length	mm	1152			1752		2906		3506	
Sound power	Lw [dB(A)] **	77									
	Cooling & Heating Lw [dB(A)]	82	83					86			
Power supply	Phase/Frequency/Voltage	3N~/50&60/400									

\*\* Sound power in heating mode, measured according to the EN12102 and under test method following the ISO9614.  
The sound pressure is calculated from the sound power level and are for information only and not considered binding.

# Pump curves

## Sound power & pressure data

Sound pressure level @ 1 m from the unit (rif. 2 x10 <sup>-5</sup> Pa)										
	Lw [dB(A)]	Lp @ 1m [dB(A)]	63 Hz	125 Hz	250 Hz	500 Hz	1 kHz	2 kHz	4 kHz	8 kHz
EWYE019CZP-A1	77	61,2	70,38	62,89	59,83	59,55	56,81	49,49	46,21	46,26
EWYE022CZP-A1	77	61,2	70,38	62,89	59,83	59,55	56,81	49,49	46,21	46,26
EWYE025CZP-A1	77	61,2	70,38	62,89	59,83	59,55	56,81	49,49	46,21	46,26
EWYE030CZP-A1	77	60,7	69,5	60,6	60,0	59,6	56,2	46,7	46,8	44,7
EWYE035CZP-A1	77	60,7	69,5	60,6	60,0	59,6	56,2	46,7	46,8	44,7
EWYE050CZP-A2	78	60,9	65,6	62,1	60,4	57,4	54,3	51,2	52,4	50,8
EWYE060CZP-A2	78	60,9	65,6	62,1	60,4	57,4	54,3	51,2	52,4	50,8
EWYE070CZP-A2	78	60,5	65,1	61,7	60,0	57,0	53,9	50,8	52,1	50,5
EWYE019CZN-A1	77	61,2	70,38	62,89	59,83	59,55	56,81	49,49	46,21	46,26
EWYE022CZN-A1	77	61,2	70,38	62,89	59,83	59,55	56,81	49,49	46,21	46,26
EWYE025CZN-A1	77	61,2	70,38	62,89	59,83	59,55	56,81	49,49	46,21	46,26
EWYE030CZN-A1	77	60,7	69,5	60,6	60,0	59,6	56,2	46,7	46,8	44,7
EWYE035CZN-A1	77	60,7	69,5	60,6	60,0	59,6	56,2	46,7	46,8	44,7
EWYE050CZN-A2	78	60,9	65,6	62,1	60,4	57,4	54,3	51,2	52,4	50,8
EWYE060CZN-A2	78	60,9	65,6	62,1	60,4	57,4	54,3	51,2	52,4	50,8
EWYE070CZN-A2	78	60,5	65,1	61,7	60,0	57,0	53,9	50,8	52,1	50,5

Model	Pump curve
EWYE019CZP-A1	A
EWYE022CZP-A1	A
EWYE025CZP-A1	A
EWYE030CZP-A1	B
EWYE035CZP-A1	B
EWYE050CZP-A2	C
EWYE060CZP-A2	C
EWYE070CZP-A2	D

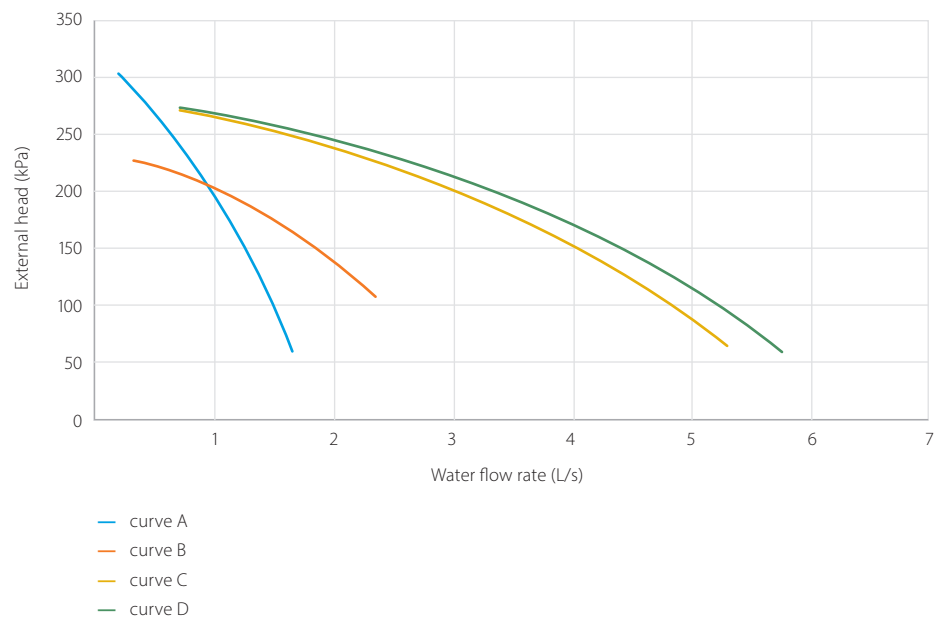



For Product, Service & Maintenance,  
Rental, and Spares enquiries:



0345 565 2700



[daikinapplied.uk](http://daikinapplied.uk)



[daikinrentalsolutions.uk](http://daikinrentalsolutions.uk)



Follow us:  
[www.linkedin.com/company/  
daikin-applied-uk-ltd/](https://www.linkedin.com/company/daikin-applied-uk-ltd/)

The present publication is drawn up by way of information only and does not constitute an offer binding upon Daikin Applied (UK). Daikin Applied (UK) Ltd has compiled the content of this publication to the best of its knowledge. No express or implied warranty is given for the completeness, accuracy, reliability or fitness for particular purpose of its content and the products and services presented therein. Specifications are subject to change without prior notice. Daikin Applied (UK) Ltd explicitly rejects any liability for any direct or indirect damage, in the broadest sense, arising from or related to the use and/or interpretation of this publication.



Daikin Applied (UK) Ltd is certified to ISO 9001 Quality Management System (QMS), ISO 14001 Environmental Management System (EMS), and ISO 45001 Occupational Health and Safety (OH&S) management systems. For the latest certificates, visit: [www.daikinapplied.uk/documents-download](http://www.daikinapplied.uk/documents-download)

